

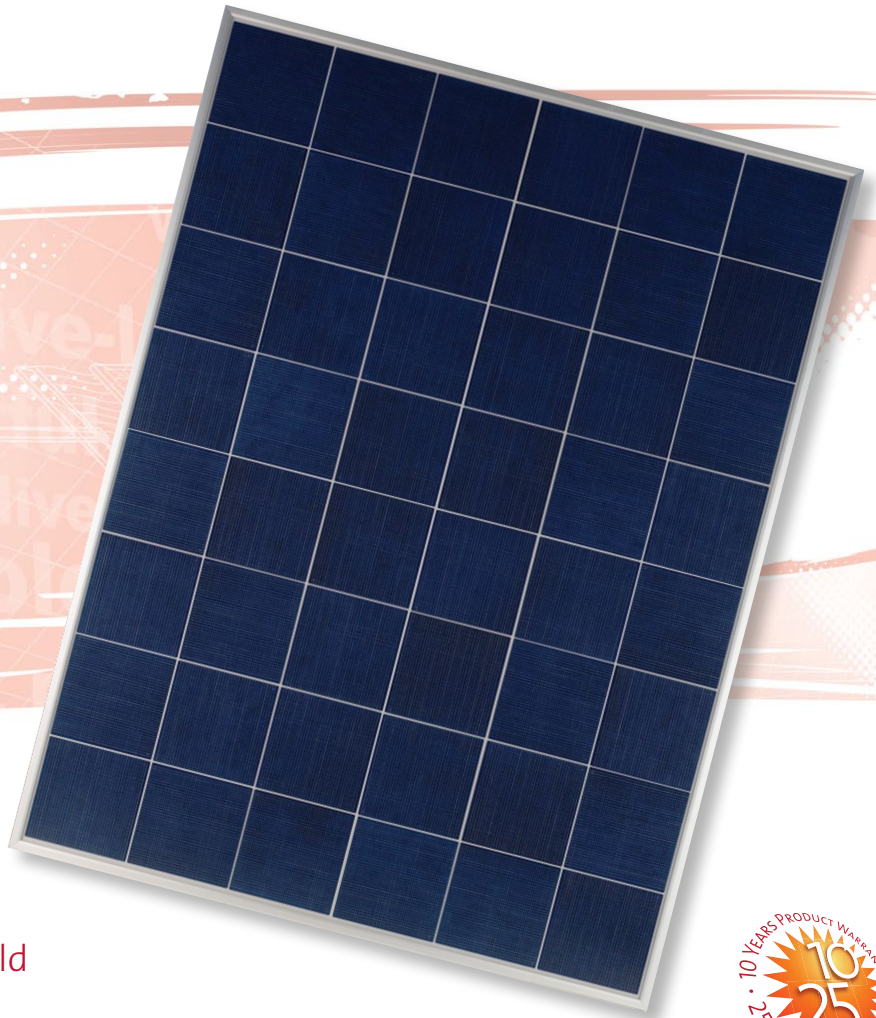

# 48MC-S ADVANCED PHOTOVOLTAIC MODULES



## 1 More Energy Every Day

- Low metallization solar cell technology
- Industry leading power collection
- High efficiency in low light conditions
- Self cooling PV cell technology results in lower operating temperature

## +2 Under Real World Conditions

- Certified salt mist resistant technology ideal for coastal areas
- Optimal protection against harsh environment in greenhouse and farming applications
- Rated for extreme snow loads with 5400 N/m<sup>2</sup> front load
- Extra strong 40mm aluminum frame

## +3 Stable Over Time

- Highly resistant backsheet with aluminum layer
- Microcrack resistant cell technology
- Thermal stress relief encapsulation technology
- Reliable PV cell interconnection – over 2100 independent electrical contacts on each cell

## +4 Lower Installation Costs

- Less space required due to best in class power density of up to 150 W/m<sup>2</sup>
- Plus sorted – get more than you paid for

# = Higher Return

### Typical Electrical Performance at STC (1000W/m<sup>2</sup>, AM 1.5 Spectrum, cell temperature 25°C)

Power Class	Watts	160	165	170	175	180	185	190	195	200
Peak Power (Wp)**	Watts	160	165	170	175	180	185	190	195	200
Max. Power Voltage (V <sub>mp</sub> )	Volts	22.60	22.95	23.04	23.40	23.70	23.82	24.00	24.20	24.38
Max. Power Current (I <sub>mp</sub> )	Amps	7.08	7.19	7.38	7.48	7.60	7.77	7.92	8.06	8.21
Open Circuit Voltage (V <sub>oc</sub> )	Volts	28.30	28.6	28.80	29.20	29.40	29.51	29.70	29.90	30.14
Short Circuit Current (I <sub>sc</sub> )	Amps	7.70	7.80	7.90	8.05	8.10	8.20	8.30	8.40	8.55

### Typical Electrical Performance (800W/m<sup>2</sup>, AM 1.5 Spectrum, cell temperature 25°C)

Power Class	Watts	160	165	170	175	180	185	190	195	200
Peak Power (Wp)**	Watts	131.17	132.83	138.47	141.72	145.19	149.14	153.13	158.37	162.99
Max. Power Voltage (V <sub>mp</sub> )	Volts	22.46	23.02	23.39	23.58	23.84	23.71	23.89	24.29	24.51
Max. Power Current (I <sub>mp</sub> )	Amps	5.84	5.77	5.92	6.01	6.09	6.29	6.41	6.52	6.65
Open Circuit Voltage (V <sub>oc</sub> )	Volts	28.04	28.25	28.58	28.97	29.10	29.22	29.41	29.73	29.96
Short Circuit Current (I <sub>sc</sub> )	Amps	6.23	6.27	6.36	6.48	6.52	6.59	6.67	6.75	6.82

\*\* Production tolerance before module sorting: ±3.5% of Pmax

### Mechanical Specifications

Cells	48 cells, multicrystalline silicon, 156mm square (6+ inches)
Glass	Solar glass (tempered)
Module Connection	MC Type IV compatible
Frame	Anodized aluminum
Backsheet	Multi-layer film compound with aluminum layer

### Qualification Test Parameters

Temperature Cycling Range	-40°C to +90°C (-40°F to 194°F)
Humidity Freeze	85% rH, -40°C to +85°C (-40°F to 185°F)
Static Load Front and Back	UL: 1436pa (30lbs/ft <sup>2</sup> ), IEC: 2400N/m <sup>2</sup>
Front Loading (eg. Snow)	UL: 1436pa (30lbs/ft <sup>2</sup> ), IEC: 5400N/m <sup>2</sup>
Fire Class (UL only)	C
Salt Mist Test (IEC 61701)	Pass
Protection Classification	IP 65

### Additional Characteristics

Short Circuit Current Temp. Coefficient* (TC I <sub>sc</sub> )	2.67mA/K
Open Circuit Voltage Temp. Coefficient* (TC V <sub>oc</sub> )	-0.10V/K
Max. Power Temp. Coefficient* (TC P <sub>mpp</sub> )	-0.44%/K
Positive Module Sorting	in increments of +5Wp
Module Maximum Fuse Series (Amps)	15A
Module Efficiency	up to 15.5%
Reduction of Efficiency (from 1000W/m <sup>2</sup> to 200W/m <sup>2</sup> )	<4%
Nominal Operating Cell Temperature (NOCT)	42.9°C
Maximum System Voltage	UL: 600V, IEC: 1000V

\* based on 175W

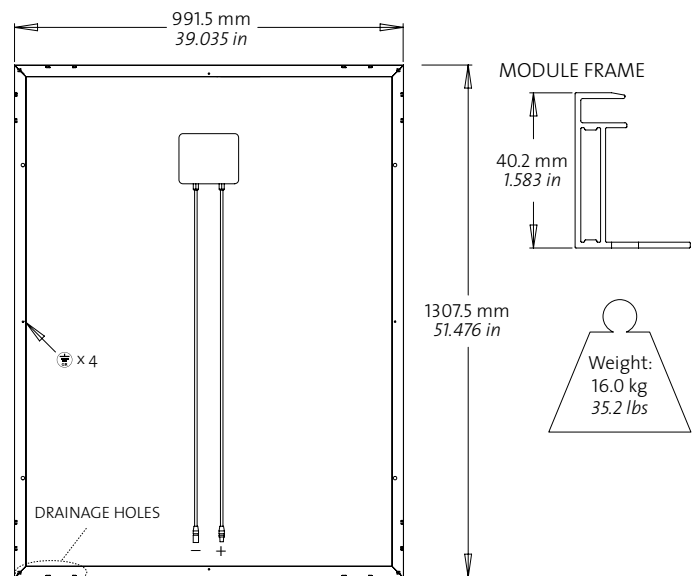

NOTE: All dimensions are accurate within ±1.5mm tolerance unless otherwise stated. Product dimensions in imperial inches (conversion of 1mm equals 0.03937in, 1kg equals 2.2lbs) are provided for information purposes only.

For more details, see Installation Manual.

Specifications and design are subject to change without notice. The features, functions and appearance of the Day4 48MC-S module may differ from details given due to continual product development.



Pending